



Ideali per fresare, sgrossare, rifinire e sbavare acciaio, acciaio inossidabile, alluminio, leghe leggere (si raccomanda un'attenta selezione del taglio in funzione del materiale da lavorare).

Realizzate in metallo duro (Carburo di Tungsteno) micrograna K20 (durezza >90 HRC).

Monoblocco fino al \varnothing 6 mm; con gambo in acciaio saldato a partire dal \varnothing 8 mm.

Misure gambo: 6x40 mm o 6x150 mm (Serie Lunga). Disponibili in quattro tagli (n. 1, 3, 4, 6).

Misure gambo minifrese \varnothing 3 mm



TG-1

Per lavorare alluminio, leghe leggere, materie plastiche e per sgrossare acciaio non temprato.



TG-3

Per lavorare acciaio temprato ad alta resistenza.
Per Ripassare cordoni di saldatura.





TG-4

Taglio incrociato "a diamante" che produce un truciolo corto e previene l'intasamento.
Per lavori di finitura su acciai temprati e per ripassare saldature ad alta resistenza.



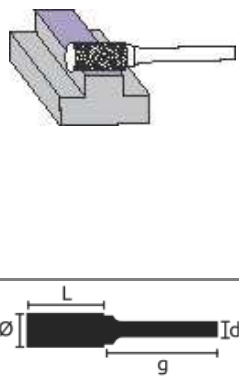

TG-6

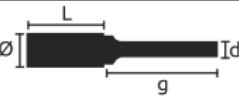
Taglio incrociato con ottima capacità di asportazione e buon grado di finitura.
Per la lavorazione di acciai temprati.

FORMA A cilindrica											
	cod. art.	taglio	Ø mm	L mm	g mm		cod. art.	taglio	Ø mm	L mm	g mm
	NA30414	3	4	14	40		NA11225	1	12	25	40
	NA40414	4					NA31225	3			
	NA10616	1	6	18	40		NA41225	4			
	NA30616	3					NA61225	6			
	NA40616	4					NA11625	1	15	25	40
	NA60616	6					NA31625	3			
	NA10820	1	8	20	40		NA41625	4			
	NA30820	3					NA61625	6			
	NA40820	4					NA12025	1	20	25	40
	NA60820	6					NA32025	3			
	NA11020	1	10	20	40		NA42025	4			
	NA31020	3									
NA41020	4										
NA61020	6										



d: gambo Ø 6 mm

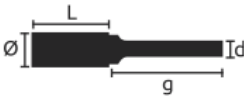

FORMA B cilindrica con taglio in testa											
	cod. art.	taglio	Ø mm	L mm	g mm		cod. art.	taglio	Ø mm	L mm	g mm
	NB30414	3	4	14	40		NB31020L	3	10	20	150
	NB40414	4					NB41020L	4			
	NB10616	1	6	18	40		NB11225	1	12	25	40
	NB30616	3					NB31225	3			
	NB40616	4					NB41225	4			
	NB60616	6					NB61225	6			
	NB30616L	3	6	18	150		NB31225L	3	12	25	150
	NB40616L	4					NB41225L	4			
	NB10820	1	8	20	40		NB11625	1	15	25	40
	NB30820	3					NB31625	3			
	NB40820	4					NB41625	4			
	NB60820	6					NB61625	6			
NB30820L	3	8	20	150	NB12025	1	20	25	40		
NB40820L	4				NB32025	3					
NB11020	1	10	20	40	NB42025	4					
NB31020	3				NB42025	6					
NB41020	4										
NB61020	6										

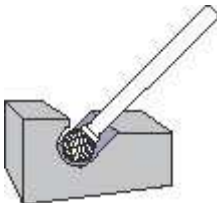
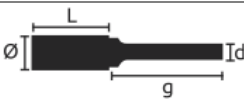

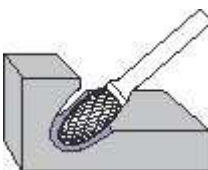
d: gambo Ø 6 mm

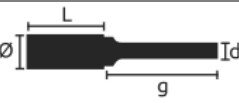

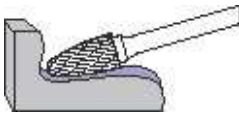
FORMA C Cilindrica testa raggiata															
	cod. art.	taglio	Ø mm	L mm	g mm		cod. art.	taglio	Ø mm	L mm	g mm				
	NC30414	3	4	14	40		NC11020	1	10	20	40				
	NC40414	4					NC31020	3				NC41020	4	NC61020	6
	NC10616	1	6	18	40		NC41020L	4				10	20	150	
	NC30616	3					NC11225	1							12
	NC40616	4					NC31225	3	NC41225	4	NC61225	6			
	NC60616	6					NC31225L	3	12	25	150				
	NC30616L	3					NC41225L	4				NC11625	1	15	
	NC40616L	4					NC31625	3	NC41625	4	NC61625	6			
	NC10820	1	8	20	40		NC12025	1	20	25	40				
	NC30820	3					NC32025	3				NC42025	4		NC62025
	NC40820	4					NC32025L	3				15	25	40	
	NC60820	6					NC41625L	4							NC12025L
	NC30820L	3				NC42025L	4	NC32025L				3	NC42025L	4	NC62025L
	NC60820L	6	NC42025L	4	NC62025L	6	NC42025L	4	NC62025L	6					

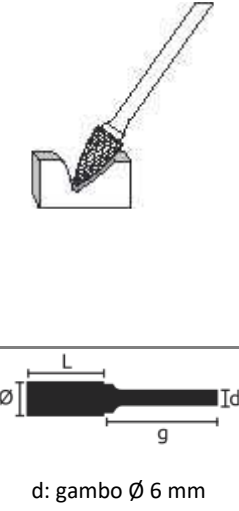

FORMA D Sfrica																	
	cod. art.	taglio	Ø mm	L mm	g mm		cod. art.	taglio	Ø mm	L mm	g mm						
	ND30403	3	4	3	40		ND41009L	4	10	8	150						
	ND40403	4					ND11210	1				12	10	40			
	ND10605	1	6	5	40		ND31210	3	ND41210	4	ND61210				6		
	ND30605	3					ND31210L	3	12	10	150						
	ND40605	4					ND41210L	4							ND11614	1	15
	ND60605	6					ND31614	3	ND41614	4	ND61614	6					
	ND30605L	3					6	5	150	ND31614L	3	15	14	150			
	ND40605L	4								ND41614L	4				ND12018	1	
	ND10807	1	8	7	40		ND32018	3	ND42018	4							
	ND30807	3					ND41009	4	10	8	40						
	ND40807	4					ND31009	3				ND41009	4	ND61009	6		
	ND60807	6					ND41009L	4				ND31009L	3	ND41009L	4	ND61009L	6
	ND40807L	4				ND41009L	4	ND61009L				6	ND41009L	4	ND61009L	6	

FORMA E Ovale											
	cod. art.	taglio	Ø mm	L mm	g mm		cod. art.	taglio	Ø mm	L mm	g mm
	NE30406	3	4	6	40		NE31220L	3	12	20	150
	NE40406	4					NE41220L	4			
	NE10610	1	6	10	40		NE11220	1	12	20	40
	NE30610	3					NE31220	3			
	NE40610	4					NE41220	4			
	NE60610	6					NE61220	6			
	NE30610L	3	6	10	150		NE11625	1	15	25	40
	NE40610L	4					NE31625	3			
	NE10813	1	8	13	40		NE41625	4			
	NE30813	3					NE61625	6			
	NE40813	4					NE12025	1	20	25	40
	NE60813	6					NE32025	3			
	NE30813L	3	NE42025	4							
	NE40813L	4	8	13	150						
	NE11016	1					10	16	40		
	NE31016	3									
	NE41016	4									
	NE61016	6									

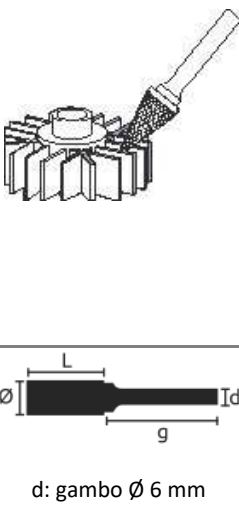

FORMA H a testa raggiata											
	cod. art.	taglio	Ø mm	L mm	g mm		cod. art.	taglio	Ø mm	L mm	g mm
	NH30414	3	4	14	40		NH31020L	3	10	20	150
	NH40414	4					NH41020L	4			
	NH10618	1	6	18	40		NH11225	1	12	25	40
	NH30618	3					NH31225	3			
	NH40618	4					NH41225	4			
	NH60618	6					NH61225	6			
	NH30618L	3	6	18	150		NH31225L	3	12	25	150
	NH40618L	4					NH41225L	4			
	NH10818	1	8	18	40		NH11630	1	15	30	40
	NH30818	3					NH31630	3			
	NH40818	4					NH41630	4			
	NH60618	6					NH61630	6			
	NH30818L	3	8	18	150		NH12030	1	20	30	40
	NH40818L	4					NH32030	3			
	NH11020	1	10	20	40		NH42030	4			
	NH31020	3									
	NH41020	4									
	NH61020	6									

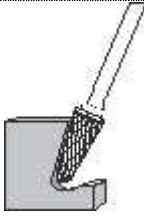

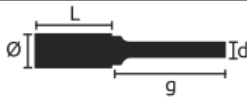
FORMA K Testa a punta	cod. art.	taglio	Ø mm	L mm	g mm		cod. art.	taglio	Ø mm	L mm	g mm			
	NK30414	3	4	14	40	d: gambo Ø 6 mm	NK11225	1	12	25	40			
	NK40414	4					NK31225	3				NK41225	4	NK61225
	NK10616	1	6	20	40		NK41225L	4				12	25	150
	NK30616	3					NK11630	1				15	30	40
	NK40616	4					NK31630	3						
	NK60616	6					NK41630	4						
	NK40616L	4					6	15	150					
	NK10818	1	8	22	40		NK12030	1	20	25	40			
	NK30818	3					NK32030	3						
	NK40818	4					NK42030	4						
	NK60818	6												
	NK11020	1	10	20	40									
	NK31020	3												
	NK41020	4												
	NK61020	6												

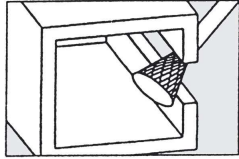
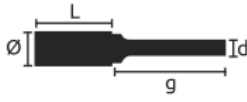
FORMA L conica	cod. art.	taglio	Ø mm	L mm	g mm		cod. art.	taglio	Ø mm	L mm	g mm				
	NL10616	1	6	22	40	d: gambo Ø 6 mm	NL11225	1	12	25	40				
	NL60616	3					NL31225	3				NL41225	4	NL61225	6
	NL40616	4					NL11625	1				15	25	40	
	NL60616	6					NL31625	3							
	NL10818	1	8	20	40		NL41625	4							
	NL30818	3					NL61625	6							
	NL40818	4					NL32025	3	20	25	40				
	NL60818	6					NL42025	4							
	NL11020	1	10	20	40										
	NL31020	3													
	NL41020	4													
	NL61020	6													

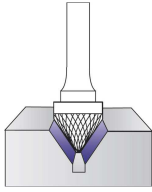
FORMA U conica Testa raggiata	cod. art.	taglio	Ø mm	L mm	g mm		cod. art.	taglio	Ø mm	L mm	g mm		
													NU30416
	NU40416	4					NU41020L	4					
	NU10620	1	6	20	40		NU11225	1	12	33	40		
	NU30620	3											
	NU40620	4											
	NU60620	6											
	NU10820	1	8	25	40		NU31225L	3	12	30	150		
	NU30820	3											
	NU40820	4											
	NU60820	6											
	NU11020	1	10	30	40		NU11630	1	15	35	40		
	NU31020	3											
	NU41020	4											
	NU61020	6											
						d: gambo Ø 6 mm	NU31225L	4					
							NU41225L	4					
							NU11630	1					
							NU31630	3					
							NU41630	4					
							NU61630	6					
							NU12032	1	20	42	40		
							NU32032	3					
							NU42032	4					

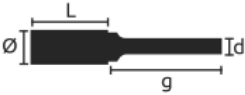
FORMA S Tronco conica	cod. art.	taglio	Ø mm	L mm	g mm	
	NS30808	3	8	8	40	
	NS40808	4				
	NS31010	3	10	10	40	
	NS41010	4				
	NS41212	4	12	12	40	
	NS41616	4	15	16	40	d: gambo Ø 6 mm

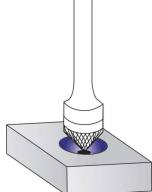
FORMA M Conica a 60°	cod. art.	taglio	Ø mm	L mm	g mm	
	NM40404	4	4	4	40	
	NM30606	3	6	6	40	
	NM40606	4				
	NM30808	3	8	8	40	d: gambo Ø 6 mm
	NM31010	3	10	8	40	
	NM41010	4				
	NM31212	3	12	11	40	
	NM41212	4				
	NM31616	3	15	15	40	
	NM41616	4				

FORMA N Conica a 90°	cod. art.	taglio	Ø mm	L mm	g mm	
	NN30402	3	4	2	40	
	NN40603	4	6	3	40	
	NN31005	3	10	5	40	d: gambo Ø 6 mm
	NN41005	4				
	NN31206	3	12	6	40	
	NN41206	4				
	NN31608	3	15	8	40	
	NN41608	4				